



velonex
APPLICATION NOTES
FOR
HIGH POWER PULSE GENERATORS



VELONEX

APPLICATION NOTE V-13

PEAK READING VOLTAGE METER CALIBRATION

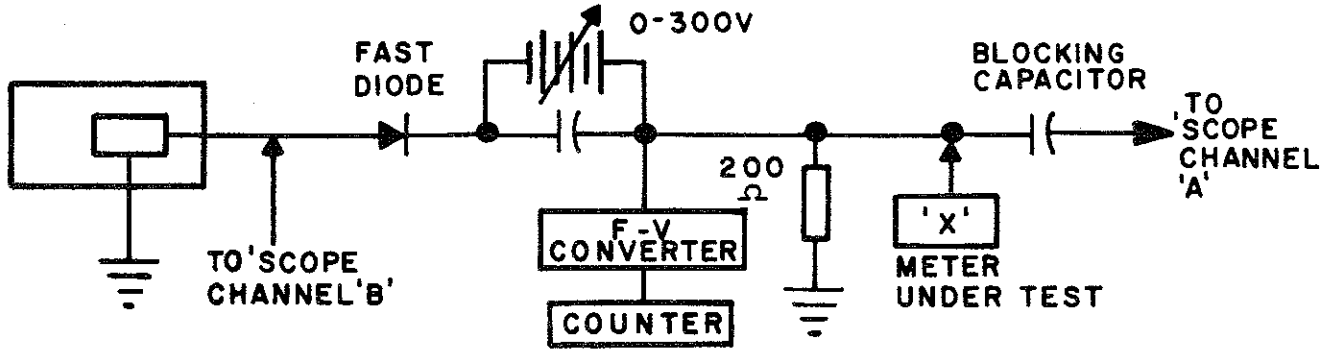

Figure 1.

To accurately calibrate peak reading voltmeters and their associated attenuators, a wide range High Power Pulse Generator which has a minimum pulse top width of 30 nanoseconds is necessary. The most sensitive peak reading voltmeter will detect a pulse FLAT top of 50 nanoseconds.

Primary and secondary standards groups need to make this measurement per Figure 1 to certify calibration of HP and Ballentine Peak Reading Voltmeters.

Figure 1 shows the circuit used by National Bureau of Standards, Boulder, Colorado in calibrating the peak reading voltmeters. The pulse is set at a suitable level and the DC voltage is raised until the pulse disappears on the oscilloscope trace. See typical wave shape presentations showing oscilloscope presentation before and at balance.



(1) Wave Form - Channel B

Wave shape will have overshoot approximately 10% if input capacity of oscilloscope or probe is more than 10 pfd.

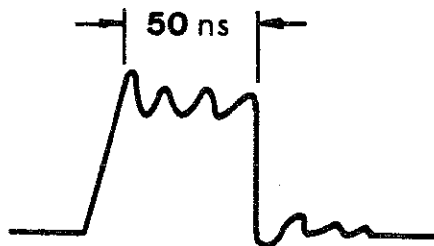

(2) Wave Form Channel A

Zero DC



Wave Form Channel A

Before Balance



Wave Form Channel A

At Balance

Ringings on pulse top can be reduced by adding bypass capacitors across power supply output terminals.

The DC voltage level is then accurately measured by a digital voltmeter. The DC voltage is then reduced to zero and the peak reading voltmeter is connected as indicated.

The peak reading voltmeter indication of voltage is then compared to the value noted in the calibration sequence above.

Note that if the pulse width is varied the pulse amplitude will vary slightly and the measuring system should be calibrated.

VELONEX

APPLICATION NOTE V-14

TRANSIENT NOISE SUSCEPTIBILITY TESTING

115V 400 Cycle, 60 Cycle

POWER LINE TESTS

Many of the new military and commercial specifications recognize a problem that has existed for some time; namely, high voltage pulses generated by interconnected equipment, which is reflected into the power line. Some electronic gear is susceptible to a fast rise time pulse, either aiding or subtracting from a 115 volt sinewave power bus. In some cases, these pulses tend to be amplified in the equipment or initiate switching. New requirements spell out that pulses of this type must not interfere with normal operation.

It is possible to test electronic equipment for transient susceptibility by using a VELONEX Model 350 Pulse Generator connected to synchronize with a power line (See Fig. 1). The plug-in recommended is the V-1010 or the V-1009, depending on circuit impedance.

Typical output pulse waveforms on a 400 cycle power supply are noted:

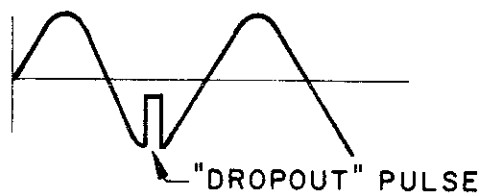
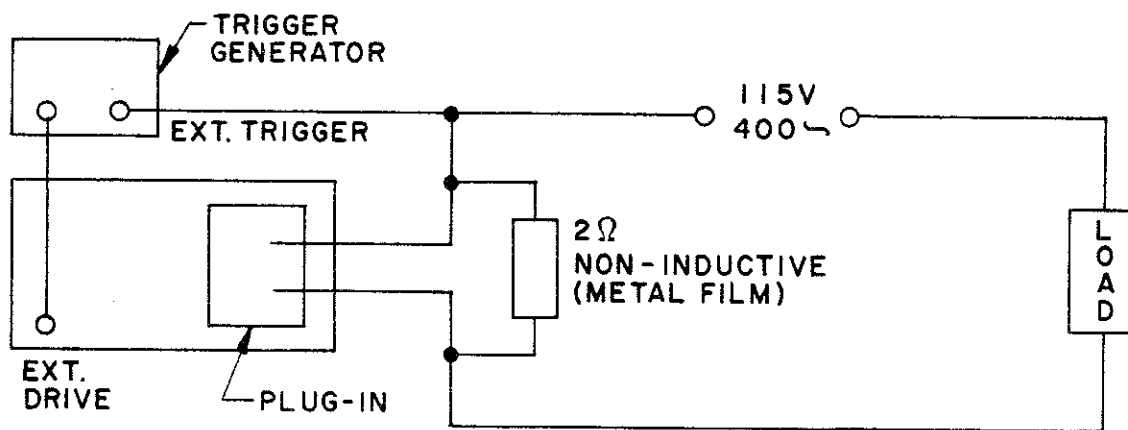

Figure 1.



VELONEX
APPLICATION NOTE V-15
AVALANCHE TRANSISTOR EVALUATION

To test a device in the avalanche region, it is important that the device dissipate the same amount of energy in the reverse direction as it does in the forward direction. Common static tests are not sufficient to define avalanche characteristics. In many instances it is noted that devices exhibit clear XY scope presentation and yet fail on the reverse pulse conditions.

The usual failures of the semiconductor devices, when subjected to avalanche testing, are due to poor surface preparation and poor bulk characteristics of the semiconductor material that forms the PN junction.

In an avalanche device the surface voltage breakdown must be higher than the bulk voltage breakdown, i.e., when an overvoltage is applied in a reverse direction. In practice the reverse voltage transient should switch the device into conduction and thus maintain the voltage below a dangerous level. A properly processed junction can dissipate kilowatts of energy in the reverse direction for a short time duration without destroying itself.

A typical application would be one in which a 1,000 volt pulse is applied at a peak current of 1.0 amperes for a pulse width of 250 microseconds on a device which is typically rated at 10 milliamps at 1,000 volts under steady state conditions.

A Model 350 with a direct output plug-in V-1097 is used in this application.

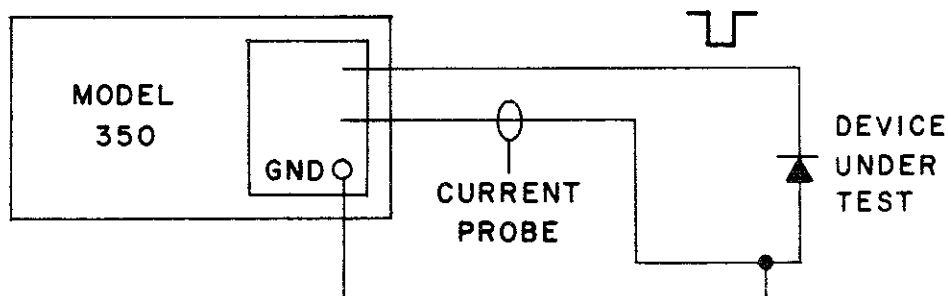

JULY 1967

VELONEX

APPLICATION NOTE V-19

PULSE TRANSFORMER TESTING

Almost every circuit designer has encountered the problem of the pulse transformer that 'meets the specs'...but doesn't do the job. One primary reason: the lack of a really accurate method of measuring pulse inductance.

To predict and control pulse droop in transformer coupled circuits and pulse width in certain types of transistor and vacuum tube regenerative blocking oscillator circuits, you need accurate knowledge of the coupling transformer's pulse inductance. Attempts to perform this measurement on sine wave impedance bridges have yielded varying results, depending on the type of core (gapped or ungapped), the type of core material, the core's previous magnetic history. The inconsistency is due to the small signal incremental nature of the typical alternating current impedance bridge measurement. The inductance indicated by this type of instrument is a function of the slope and location of the minor hysteresis loop traversed by the core flux. In most pulse applications, rather large changes of flux are encountered in which the excursions are unidirectional from an established remnant flux point. The slope, shape, and location of the pulse hysteresis loop can be radically different from its sine wave counterpart.

The Model 350 and Model 380 as shown in Figure 1 offer an excellent means of measuring pulse inductance, the key parameter in measuring pulse circuit performance.

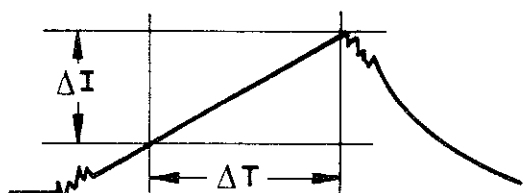
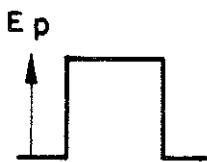
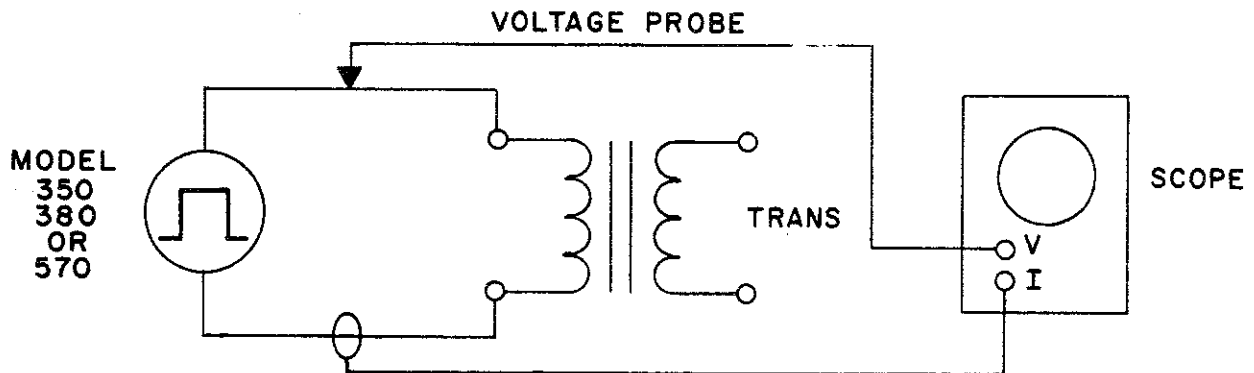

$$L_p = \frac{E_p}{\Delta} \frac{\Delta T}{I}$$

L_p = Pulse Inductance in henries.
 E = Peak Pulse Voltage - in volts.
 T = Time in seconds.
 I = Current in Amperes

VELONEX
APPLICATION NOTE V-20
MICROWAVE TUBE PULSE MODULATION

Many high power microwave tubes may be pulse modulated with the Model 350 and 570 Power Pulse Generator. Normally, the collector helix of the TWT is connected to ground, while the cathode is at an elevated voltage.

Figure 1 shows a typical arrangement for TWT grid pulsing in which the bias current flows through the secondary winding of the Model 350 plug-in. The grid bias current is normally very low and will not affect the output waveform. Note that the output plug-in must be rated for 10,000 volts DC working.

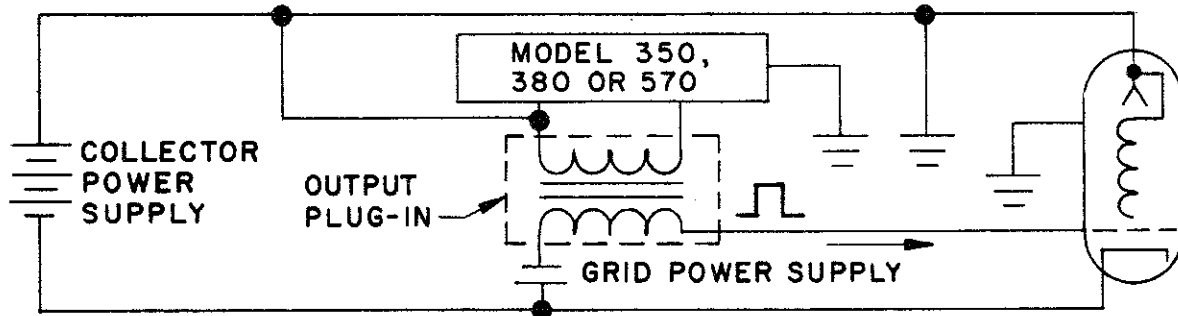

Figure 1.

Figure 2 shows another arrangement for TWT grid pulsing in which the bias current is DC blocked by capacitor "C". The pulse is capacitively coupled to the grid and must be of adequate size to minimize pulse droop. Note that the plug-in of the Model 350 need not be rated for 10,000 volts DC working.

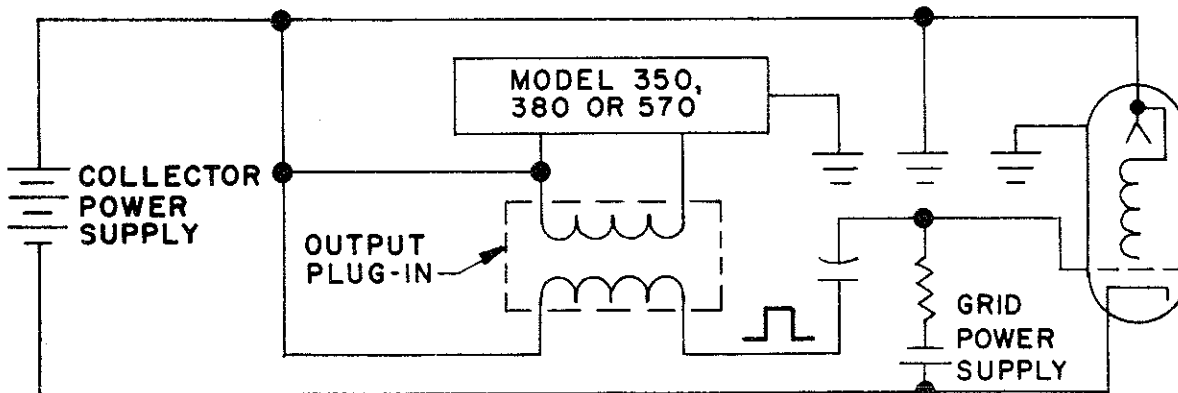

Figure 2.

VELONEX

APPLICATION NOTE V-22

PLUG-INS FOR MODELS 350 & 570

DC ISOLATION VOLTAGE RATINGS

The secondaries of most output plug-ins may be used in series with a DC bias voltage and load. Values are given for the maximum DC voltage which may be used of the same or opposite polarity of the pulse.

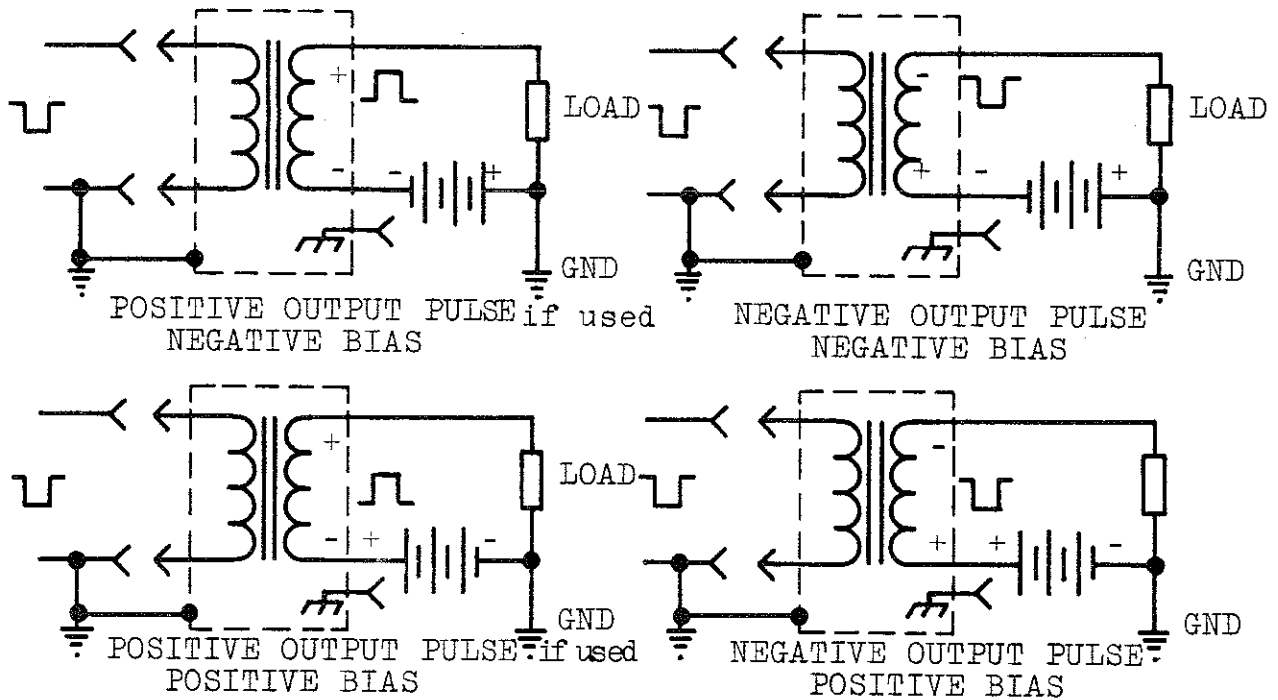

TYPICAL CONNECTIONS

Note that Plug-Ins V-1006, V-1013 and V-1071 have two secondaries bifilar wound for microwave tube pulsing. The maximum voltage difference between these two windings must be limited to 1000 VDC. Therefore, windings 3-4 and 5-6 will withstand a maximum of 1000 volts differential.

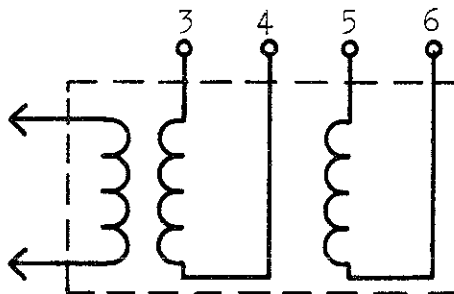

SCHEMATIC FOR PLUG-INS V-1006, V-1013 & V-1071

APPLICATION NOTE V-22 - PAGE 2

<u>MODEL NUMBER</u>	<u>OUTPUT POLARITY</u>	<u>NOMINAL PULSE VOLTAGE</u>	<u>MAXIMUM POSITIVE BIAS DC VOLTS</u>	<u>MAXIMUM NEGATIVE BIAS DC VOLTS</u>
1005	Positive	19,000	3000	0
1006	Pos. or Neg.	1,700	5000	5000
1009	Pos. or Neg.	190	100	3000
1010	Pos. or Neg.	85	100	1000
1013	Pos. or Neg.	1,900	3000	5000
1014	Pos. or Neg.	85	100	1000
1027	Positive	550	1000	3000
1028	Positive	500	1000	3000
1058	Pos. or Neg.	190	0	500
1071	Pos. or Neg.	1,700	3000	3000
1077	Positive	15,000	0	500
1078	Positive	5,000	500	5000
1083	Positive	5,000	500	3000
1088	Positive	5,000	5000	5000
1089	Positive	500	3000	3000
1092	Negative	500	3000	3000
*1094	Positive	950	1000	5000
*1095	Positive	950	100	3000
*1096	Positive	900	1000	3000
1097	Negative	2,000	0	0
1098	Negative	19,000	3000	0
1102	Negative	2,000	1000	3000
1110	Negative	5,000	5000	5000
1115	Negative	550	1000	3000
1116	Negative	550	1000	3000
1117	Negative	950	3000	3000
1118	Negative	950	1000	1000
1119	Negative	900	3000	3000
/1121	Negative	2,000	0	0
1124	Negative	15,000	500	0
1140	Pos. or Neg.	40	200	2000
1197	Pos. or Neg.	40	200	2000

*The Plug-In is normally furnished with a GR874 connector grounded to the front panel. For DC isolation the connector would have to be removed.

/V-1121 is a 200 ohm load Plug-In.

11/1967



VELONEX

APPLICATION NOTE V-24

MAGNETRON TUBE PULSING

The V-1006, V-1013, and V-1071 Plug-Ins have two paralleled output connections as a standard feature suitable for magnetron tube pulsing. A magnetron may be pulsed by a negative going pulse connected as shown:

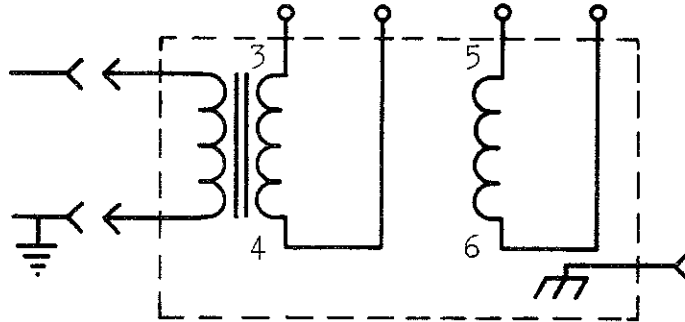

SCHEMATIC PLUG-INS V-1006, V-1013 & V-1071

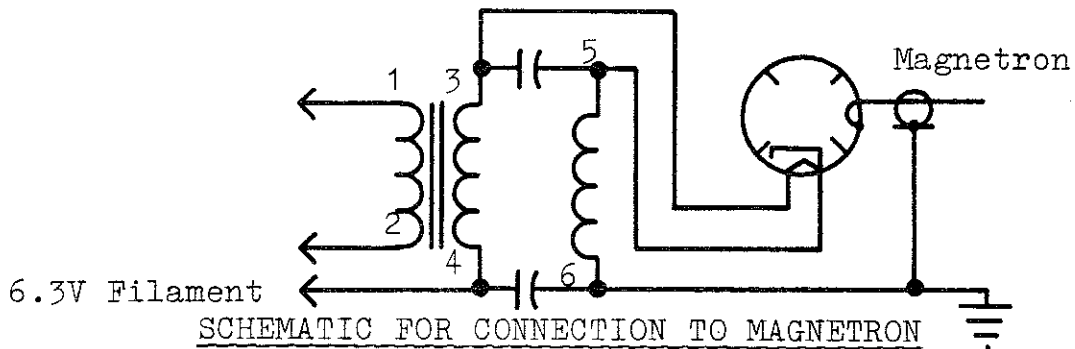

SCHEMATIC FOR CONNECTION TO MAGNETRON

A characteristic of this Plug-In is the bifilar winding on the secondary which provides filament current for the magnetron.

The maximum voltage differential between windings 3-4 and 5-6 is limited to 1000 volts DC working.

Other Plug-Ins in the standard VELONEX line are available with dual output windings to special order.



VELONEX

APPLICATION NOTE V-32

HIGH POWER PULSE GENERATORS

NOMINAL INPUT AND OUTPUT IMPEDANCES

I. INPUTS - Equivalent Circuits

- A. 350 External
Trigger and
570 Gate
External Trigger

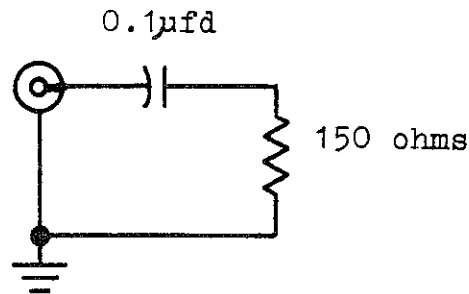

- B. 570 External
Trigger -
(Pulse)

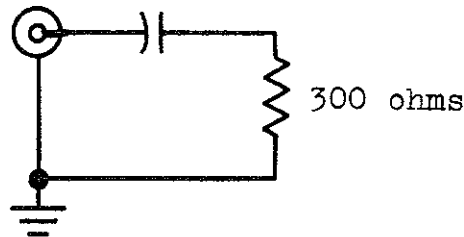

- C. 350 Ext. Drive
and 570 Ext.
Drive - (Pulse)

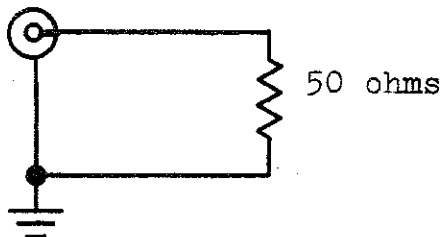

- D. 570 Gate
Ext. Drive

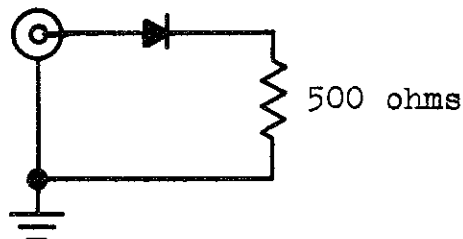



PAGE TWO -
APPLICATION NOTE V-32

E. 380 External Trigger

*L represents a low impedance path for D.C.

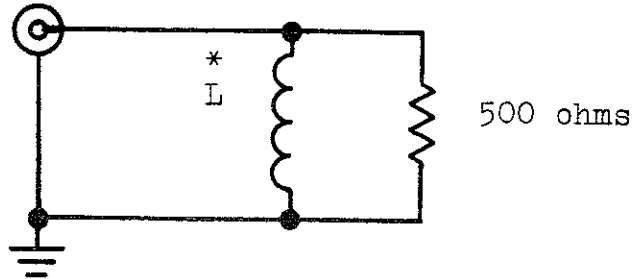

II. OUTPUT - Equivalent Circuits Model 570 and 350

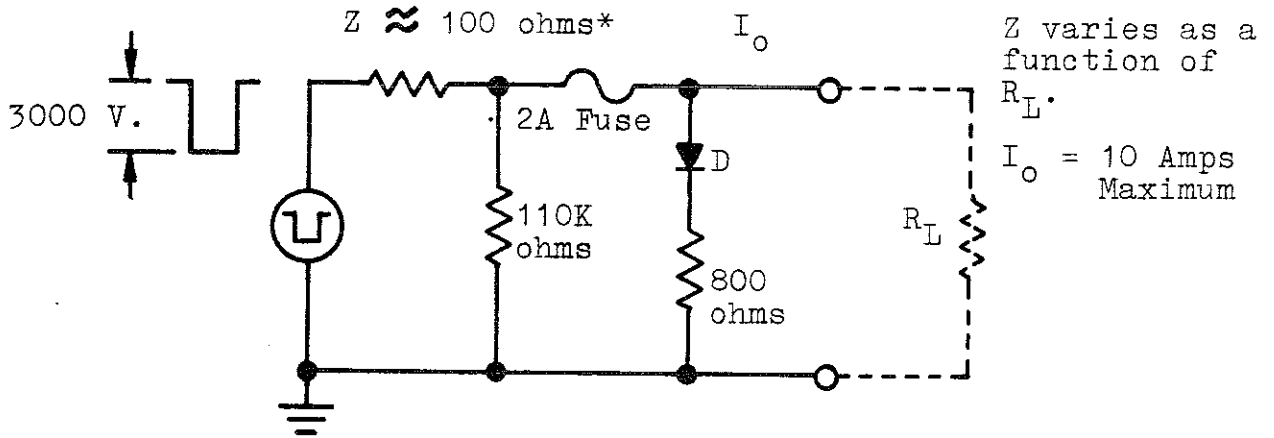

III. OUTPUT - Equivalent Circuit Model 380

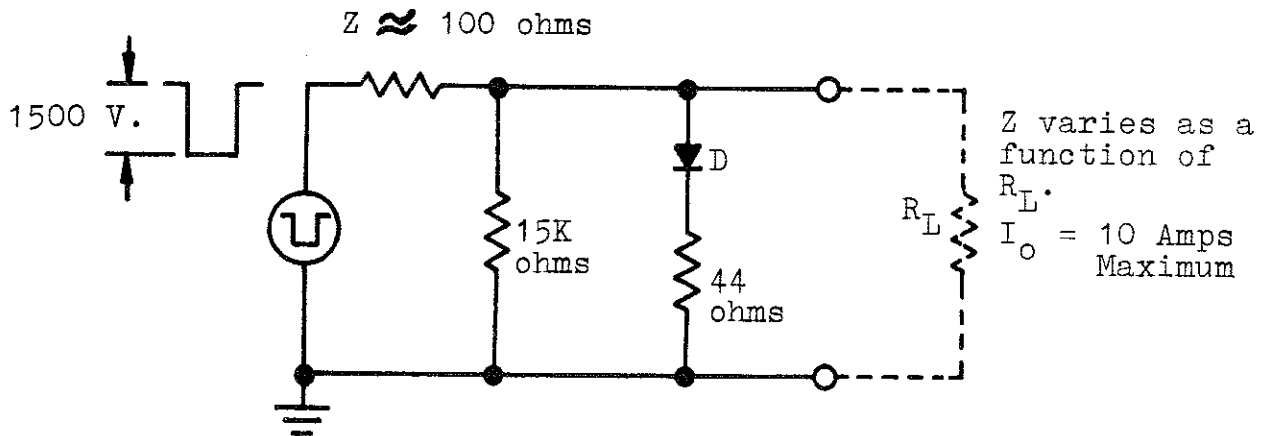



VELONEX

APPLICATION NOTE V-33

PLUG-INS FOR MODELS 350 & 570

CONNECTION & TERMINATION

GENERAL

Each Plug-In has been designed with a nominal range of pulse width of 10:1. This range is generally limited to 10:1 so as to optimize the rise and fall time of the Plug-In. There are two classifications of Plug-Ins: (1) those used for high current applications, and (2) those for high voltage applications.

HIGH CURRENT PLUG-INS:

The high current Plug-Ins are:

V-1197	}	For use with VELONEX 350 or 570
V-1140		
V-1014		
V-1010		
V-1058		
V-1009	}	For use with VELONEX 380
V-1260		
V-1261		
V-1262		
V-1263		

The Plug-Ins listed have output stripline terminal configurations



PAGE TWO -
APPLICATION NOTE V-33

HIGH VOLTAGE PLUG-INS

All Plug-Ins other than those listed above are high voltage devices and care must be taken to protect personnel and equipment from accidental contact to exposed connections. All units in this series are dead front constructed and screw type connections are provided. Makeshift connections or clip-leads should not be used and all load resistors should be applied well within their voltage and power ratings. (Most 2-watt resistors are rated at 700V or less under ideal conditions.)

The voltage rating of the insulated leads to the high voltage terminals should be carefully checked. The use of lead wire beyond its voltage rating can cause damage to the Plug-In, as intermittent arcing can generate voltage transients beyond the rating of the insulation system of the Plug-In.

Consider the current carrying rating of the lead wire used. It should be equal to or greater than the peak PULSE CURRENT expected. The use of multi-stranded wire is recommended to minimize series inductance. A conductor of equal size should be connected to the ground side of the load back to the ground terminal on the Plug-In panel to assure a good waveshape and minimize ringing.

Ringing with this series of Plug-Ins is sometimes the result of an excessively long lead on the 'scope probe. The shortest ground conductor should always be used with the 'scope probe.

The 'scope and instrument should always be operated from a common power bus and both grounded. Safety is compromised if the system is floated.

If the load is to be floated as shown in Application Note V-20 on Microwave Tube Pulsing the DC isolation, voltage rating on the Plug-In must not be exceeded. The DC isolation voltage ratings are noted on Application Note V-22.



VELONEX

APPLICATION NOTE V-37

MODEL 380 OPERATED IN THE PULSE BURST MODE

In some applications it will be advantageous to trigger a Model 380 by an external pulse source to provide a train of output pulses to drive heat-sensitive devices, test recovery time, and evaluate a device's natural resonant frequency.

The VELONEX Model 380, when driven externally in the pulse burst mode, has a maximum repetition rate of 400 KHz within the gated interval and a maximum duty cycle within the gated interval as noted in Figure 1.

You will note that the duty cycle within the burst is limited to 50% up to 300 kilohertz and to 20% from 300 kilohertz to 400 kilohertz.

The pulse burst output capability will find application with the Standard Plug-Ins as listed in the Model 380 Plug-In list in Table II of the latest VELONEX Bulletin V-10.

The VELONEX Model 380 driven externally by a pulse train must still have an overall duty cycle of less than 1%. If the duty cycle is exceeded, the overload will trip.

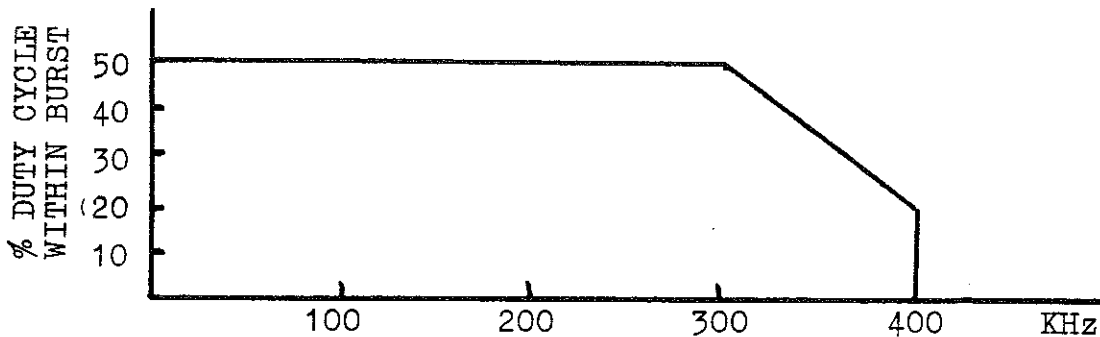

Figure 1.

% Maximum duty cycle within the pulse burst vs pulse repetition rate within the burst.

